

TM-2-17-LA0 Torque Motor

Electrical specifications

Winding code : LA	Symbol	Unit	Water cooling
Continuous torque	T_c	Nm	63
Continuous current	I_c	A_{rms}	10.3
Stall torque	T_s	Nm	52
Stall current	I_s	A_{rms}	8.2
Peak torque(for 1sec.)	T_p	Nm	105
Peak current(for 1sec.)	I_p	A_{rms}	20
Torque constant	K_t	Nm/Arms	6.67
Electrical time constant	T_e	ms	4.9
Resistance (line to line at 25°C)	R_{25}	Ω	6.8
Inductance (line to line)	L	mH	33.3
Number of poles	2p		22
Back emf constant (line to line)	K_v	Vrms/rad/s	3.85
Motor constant (at 25°C)	K_m	Nm/ \sqrt{W}	2.09
Thermal resistance	R_{th}	K/W	0.097
Thermal sensor			PTC SNM100+SNM130+Pt1000
Max. DC BUS		V_{DC}	750
Inertia of rotor	J	kgm^2	0.0023
Thermal time constant	T_{th}	s	160
Max. continuous power dissipation	P_c	W	1527
Max. peak power dissipation	P_p	W	5760
Rated speed(at 600VDC)		rpm	646

Mechanical specifications

	Symbol	Unit	Water cooling
Mass of rotor	M_r	kg	1.6
Mass of stator	M_s	kg	8
Height of stator	H_s	mm	110
Height of rotor	H_r	mm	71
Length of rotor centring fit	H	mm	15
Water temperature difference for P_c	$\Delta\theta$	K	5
Minimum water flow	q	l/min	4.4
Max. pressure drop	Δp	bar	1

T-N curve

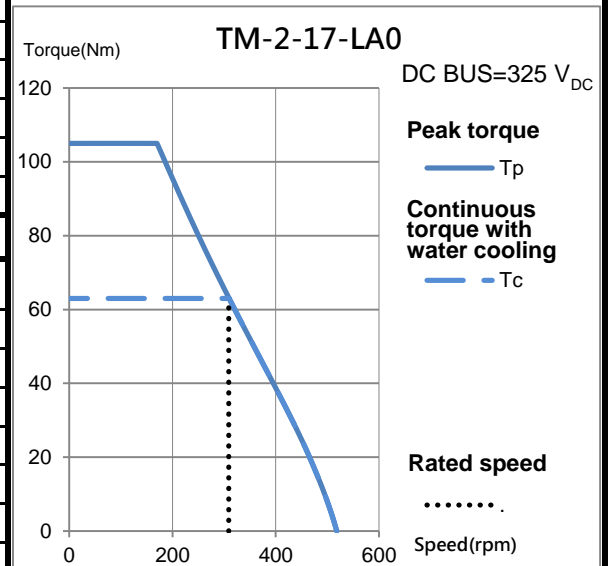
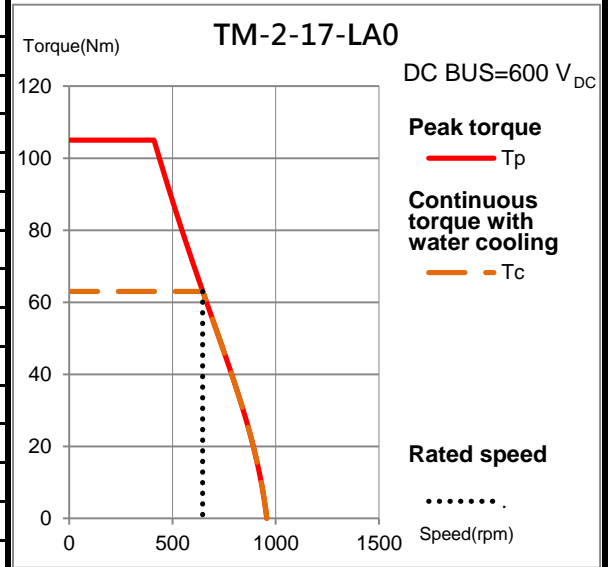

Thermal sensor

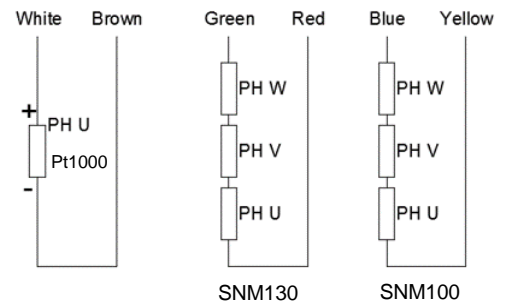
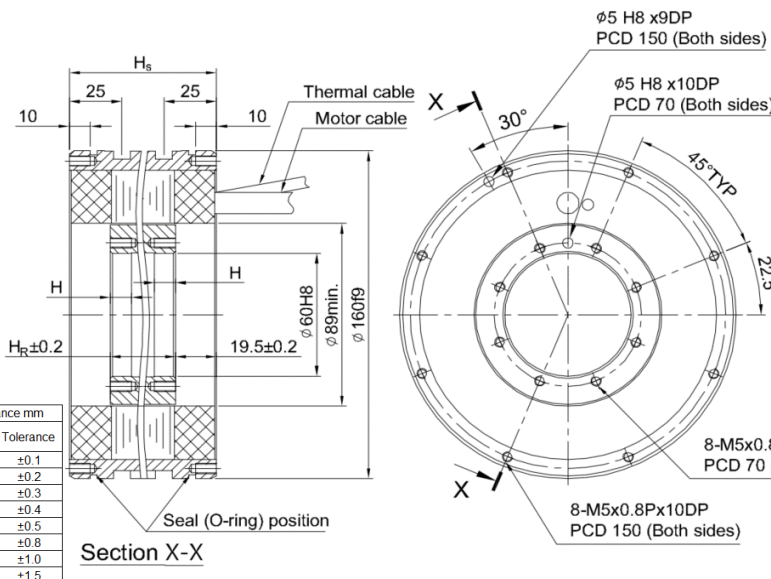

General tolerance mm	
Nominal dimension	Tolerance
~ 6	±0.1
> 6 ~ 30	±0.2
> 30 ~ 120	±0.3
> 120 ~ 300	±0.4
> 300 ~ 600	±0.5
> 600 ~ 1200	±0.8
> 1200 ~ 2400	±1.0
> 2400	±1.5

Motor wire table	
Color or wire no.	Signal
U/L1	PH U
V/L2	PH V
W/L3	PH W
Green/Yellow	GND

Except dimensions, all the specifications in the table are in ±10% of tolerance

Version: 2.00

This drawing is only for reference, detail dimensions please refer to approval drawing.

Date: 2020/10/23